

# Coaxial High Power Amplifier

## ZHL-25W-272+

50Ω 25W 20 to 2700 MHz

### The Big Deal

- Saturated power, 25W
- Wide bandwidth, 20 to 2700 MHz
- High gain, 50 dB typ.
- Self-protected from excessive drive, heat, and reverse polarity
- Withstands short and open circuit at output while delivering up to 15W



ZHL-25W-272+



ZHL-25W-272X+

### Product Overview

The ZHL-25W-272+ is a Class AB, high-power amplifier providing 25W saturated power over the 20 to 2700 MHz band, ideal for a variety of high-power test setups as well as applications including communications, radar and more. The ruggedly-designed amplifier provides unconditional stability and built-in self-protection against reverse polarity, excessive drive and overheating. It is capable of withstanding short and open circuits at output while continuously delivering 15W of power. Housed in a rugged aluminum alloy case measuring 5.6 x 8.8 x 1.2", the unit features SMA connectors and an optional heat sink and fan attachment for cooling.

### Key Features

Feature	Advantages
Wideband, usable from 10 to 2750 MHz	Suitable for a broad range of high-power, wideband applications, including test setups, communications and defense applications.
High gain, 50 dB	Enables signal amplification to 25W output without the need for multiple gain stages.
Built-in self-protection	In instances of potentially-damaging excessive drive current, heat buildup within the housing, unshorting of DC supply, and short or open loads at the output, an automatic sensing feature signals the unit to power down.
Unconditional stability	Provides reliable performance independent of input and load conditions.

# Coaxial High Power Amplifier

## ZHL-25W-272+

50Ω 25W 20 to 2700 MHz

### Features

- High power, 25 Watt at saturation
- Class AB amplifier
- Low Current consumption
- High IP3, +49 dBm typ.
- Usable from 10 MHz to 2750 MHz
- Good gain flatness, ±1.0 dB typ.
- No damage with an open or short output load while delivering up to 15W
- Shuts off when base plate temperature exceeds +85°C

### Applications

- Cellular
- PCN
- GSM
- ISM
- Lab Test

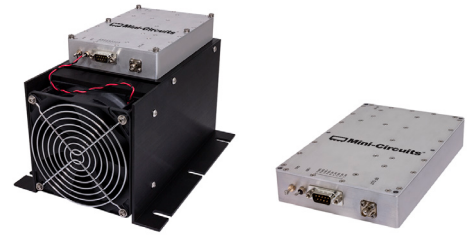

Model No.	ZHL-25W-272+	ZHL-25W-272X+ <sup>▲</sup>
Case Style	BT2119	
Connectors	SMA / Solderable pins/D-Sub Male	

**+RoHS Compliant**  
The +Suffix identifies RoHS Compliance. See our web site for RoHS Compliance methodologies and qualifications

### Electrical Specifications at 25°C

Parameter	ZHL-25W-272+			ZHL-25W-272X+			Units
	Min.	Typ.	Max.	Min.	Typ.	Max.	
Frequency Range	20		2700	20		2700	MHz
Gain <sup>1</sup>	44	50	56	44	50	56	dB
Gain Flatness	—	±1.0	±2.2		±1.0	±2.2	dB
Output Power at 1dB compression	+35	+40	—	+35	+40	—	dBm
Output Power at Saturation	+42	+44	—	+42	+44	—	dBm
Noise Figure	—	10	—	—	10	—	dB
Output third order intercept point	+44	+49	—	+44	+49	—	dBm
Input VSWR	—	2.0	—	—	2.0	—	:1
Output VSWR	—	3.5	—	—	3.5	—	:1
DC Supply Voltage	—	28	30	—	28	30	V
Supply Current <sup>2</sup>	—	3.7	6.7	—	3.5	6.5	A

1. Small signal input power -50 dBm typ.  
2. Power Supply should be capable of delivering 10A at start up.

<sup>▲</sup> Heat sink and fan not included. Alternative heat sinking and heat removal must be provided by the user to limit maximum base-plate temperature to 85°C, in order to ensure proper performance. For reference, this requires thermal resistance of user's external heat sink to be 0.2°C/W max.

### Maximum Ratings

Parameter	Ratings
Operating Temperature	-20°C to 60°C
Storage Temperature	-55°C to 100°C
Base Plate Temperature	85°C
Input RF Power (no damage)	+5 dBm

Permanent damage may occur if any of these limits are exceeded.

### D-Sub Male Connector Pin Connections\*\*

Pin Function	Label on unit	Pin #	Color	Gauge
None	N/C1, N/C2, N/C3 N/C4, N/C5	1,2,4,5	None	None
<u>Thermal Shut-Off Indication</u> Shut-Off: 2 to 5V Not Shut-Off: 0 to 0.8V	TTL Out	3	Orange	26 AWG
DC Input (+)	Vdc	6,7	Red	18 AWG
Ground	GND	8,9	Black	18 AWG

\*\*Each amplifier includes an additional D-Sub connector for mating with the amplifier.

## Outline Drawing for models with heatsink

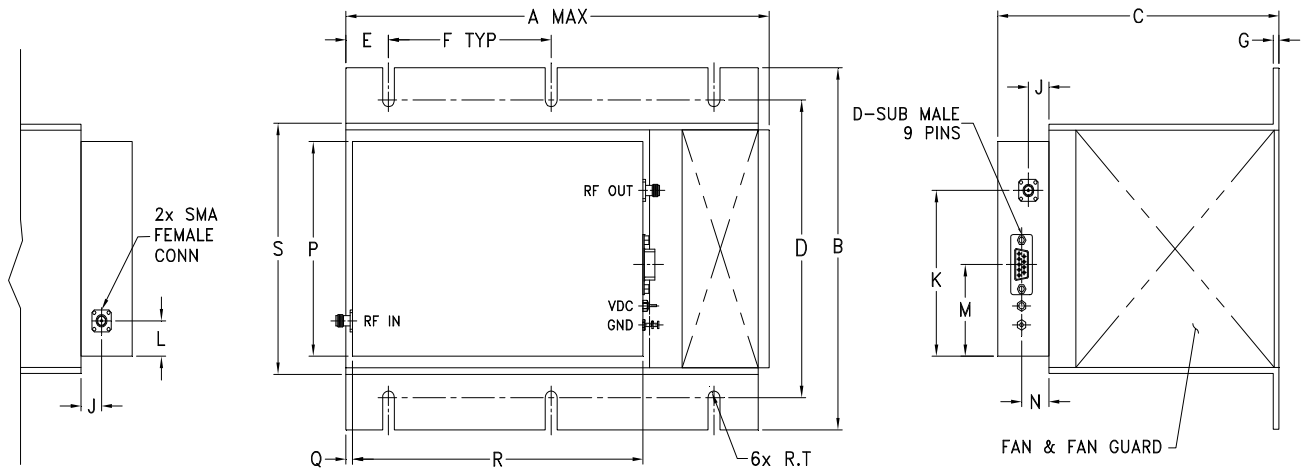

## MOUNTING INFORMATION FOR MODELS WITHOUT HEATSINK

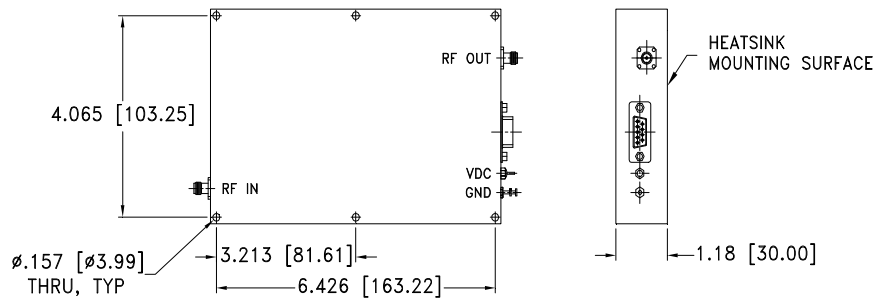

## Outline Dimensions (inch / mm)

A	B	C	D	E	F	G	J	K	L	M	N	P	Q	R	S	T	wt
9.85	7.3	6.5	6.00	.98	3.75	.13	.47	3.34	.71	1.85	.63	4.33	.2	6.69	5.1	.136	grams*
250.19	185.42	165.10	152.40	24.89	95.25	3.30	12.00	84.84	18.03	46.99	16.00	110.0	5.1	170	129.54	3.45	4565

\*880 grams without heatsink

FREQUENCY (MHz)	GAIN (dB)	DIRECTIVITY (dB)	VSWR (:1)		POUT at 1 dB COMPR. (dBm)	POUT at SAT (dBm)	NOISE FIGURE (dB)	OUTPUT IP3 (dBm)
	28V	28V	IN	OUT	28V	28V	28V	28V
20	49.60	37.40	1.38	3.88	40.10	43.30	12.90	49.80
100	48.90	51.40	1.43	4.10	40.30	43.50	10.70	48.80
500	48.50	52.00	1.07	4.90	38.20	44.30	9.70	47.00
1000	49.20	60.00	1.26	1.58	41.20	46.60	9.30	50.10
1500	48.30	53.70	1.17	1.37	41.70	46.70	9.30	50.70
2000	49.00	57.10	1.20	2.75	40.40	46.80	9.30	48.70
2500	49.00	58.90	1.12	1.47	43.00	47.10	9.60	49.60
2700	48.70	67.60	1.04	1.65	40.80	44.10	9.70	48.00

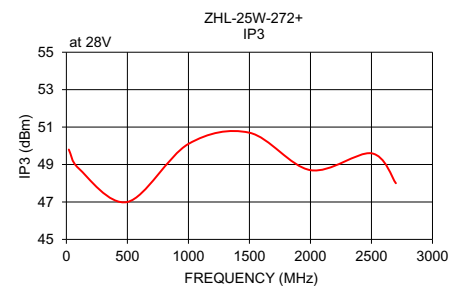
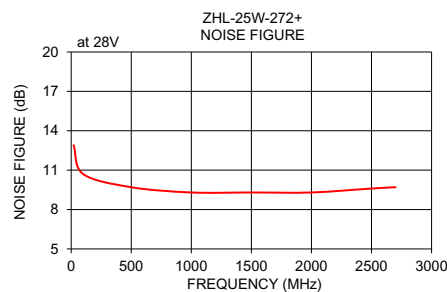
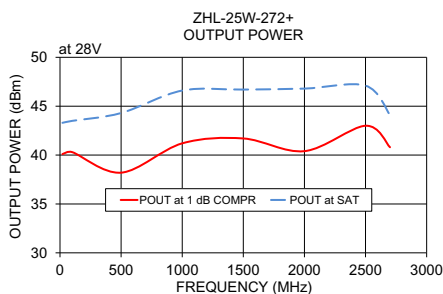
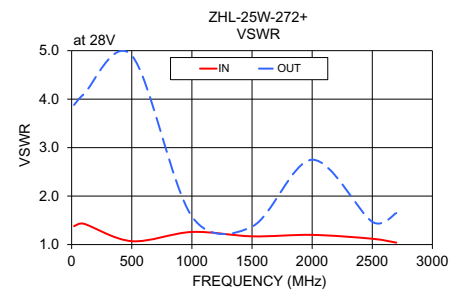
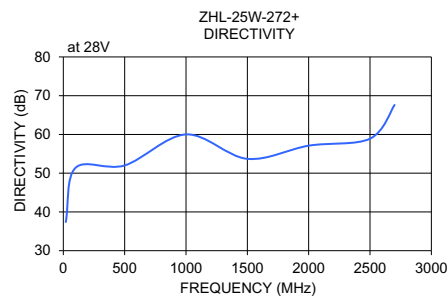
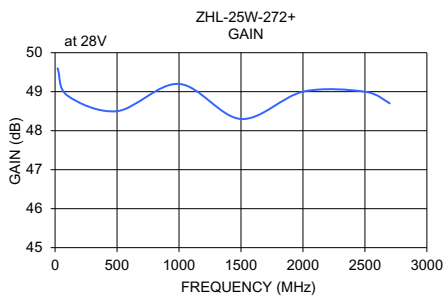

### Additional Notes

- Performance and quality attributes and conditions not expressly stated in this specification document are intended to be excluded and do not form a part of this specification document.
- Electrical specifications and performance data contained in this specification document are based on Mini-Circuit's applicable established test performance criteria and measurement instructions.
- The parts covered by this specification document are subject to Mini-Circuits standard limited warranty and terms and conditions (collectively, "Standard Terms"); Purchasers of this part are entitled to the rights and benefits contained therein. For a full statement of the Standard Terms and the exclusive rights and remedies thereunder, please visit Mini-Circuits' website at [www.minicircuits.com/MCLStore/terms.jsp](http://www.minicircuits.com/MCLStore/terms.jsp)