

We reserve all rights to this drawing, to any patents or patent registrations related hereto, and to the duplication, retransmission by third parties and misc. use. Any use of this drawing is not permitted without the written consent of STABILUS.

Intended for internal use and customer

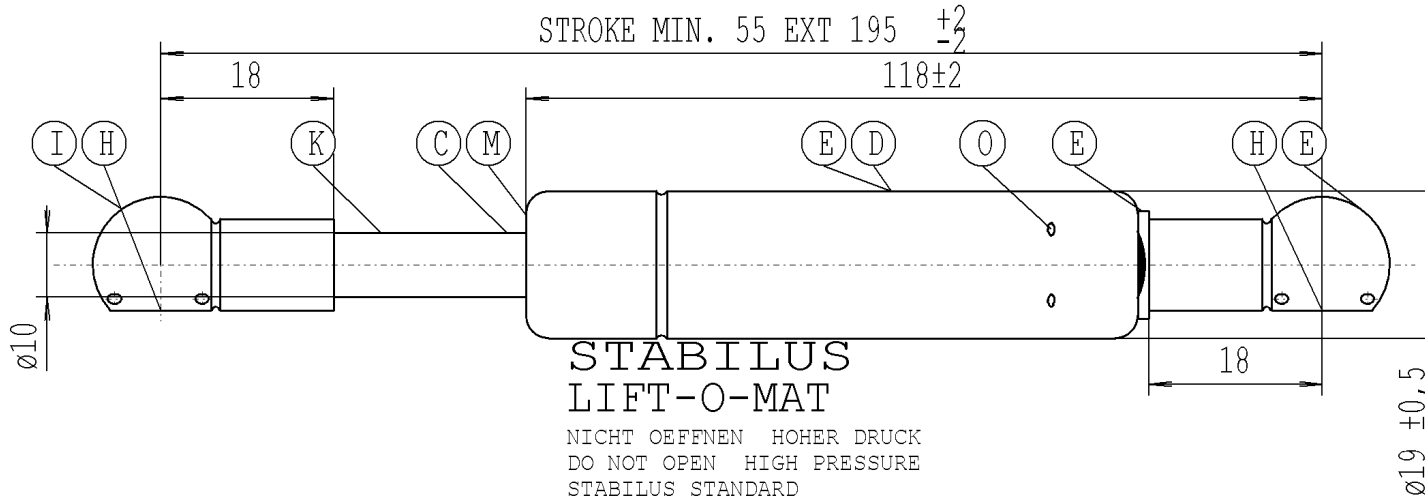

- Line up connections permissible deviation  $\pm 5$  DEG
- the Gas Spring must not be mechanically modified or damaged.
- The warning label must not be removed or obscured.
- Extension speed VS2=0,1-0,3 (m/s)
- compression and extension forces measured acc. to STAB-Spec. 10009033
- Extension speed measured according to STAB-Spec. 10005451
- Spring test with piston rod downwards
- Protect piston rod from dirt, paint and damage
- Disposal acc. to STAB-Spec.10009375
- Drawing not true-to-scale
- Observe installation instructions according to STAB-Spec. 10005593
- Ball socket to suit ball stud DIN 71803  $\varnothing 10$
- Permissible operating temperature range  $-30^{\circ}\text{C}$  to  $+80^{\circ}\text{C}$
- Installation: position any as required
- Component testing gas spring acc. STAB-Spec. 10010035
- Disassemble ball-stud to STAB-Spec.10006399
- Friction dyn. measured according to STAB-Spec. 10005458

FR1/3=200  
FR2/4=200

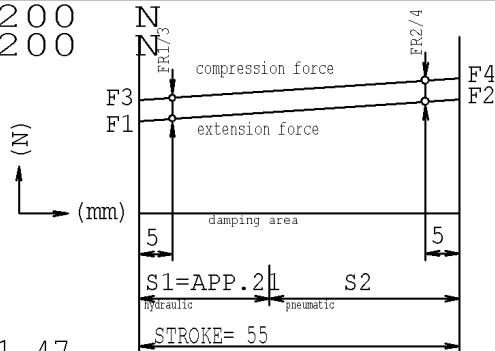

$X = F2 / F1 = 1,47$   
 $FR_{max} = F3 - F1$

- C Nislide black
  - D print white
  - E black painted
  - F tightening torque: 5 Nm
  - H greased
  - I black passivated
  - K greased
  - M border flange oiled
- ||o|dinks permissible

**Unregistered Copy**  
Print-out is not subject to the modification service

CHANGE	NEW	
	OLD	
	CHG. NO.	
	NAME	
	NO.	

**STABILUS**

Modifications in favour of technical process reserved

Forces (statically measured)

F1 (N)	F4 max (N)
extension force	compression force
1100±55	1960

DIMENSIONS WITH-OUT TOLERANCE	LIFT-O-MAT
+/-1	03 01 1016 15 057

DRAWING CHECKED

DATE 27.03.1995 NAME SCHUSTER

Document No. 10001878

305706 **E**